

USER MANUAL

LINE **S5470(F)**

LINE **S3360**

LINE **S4067**

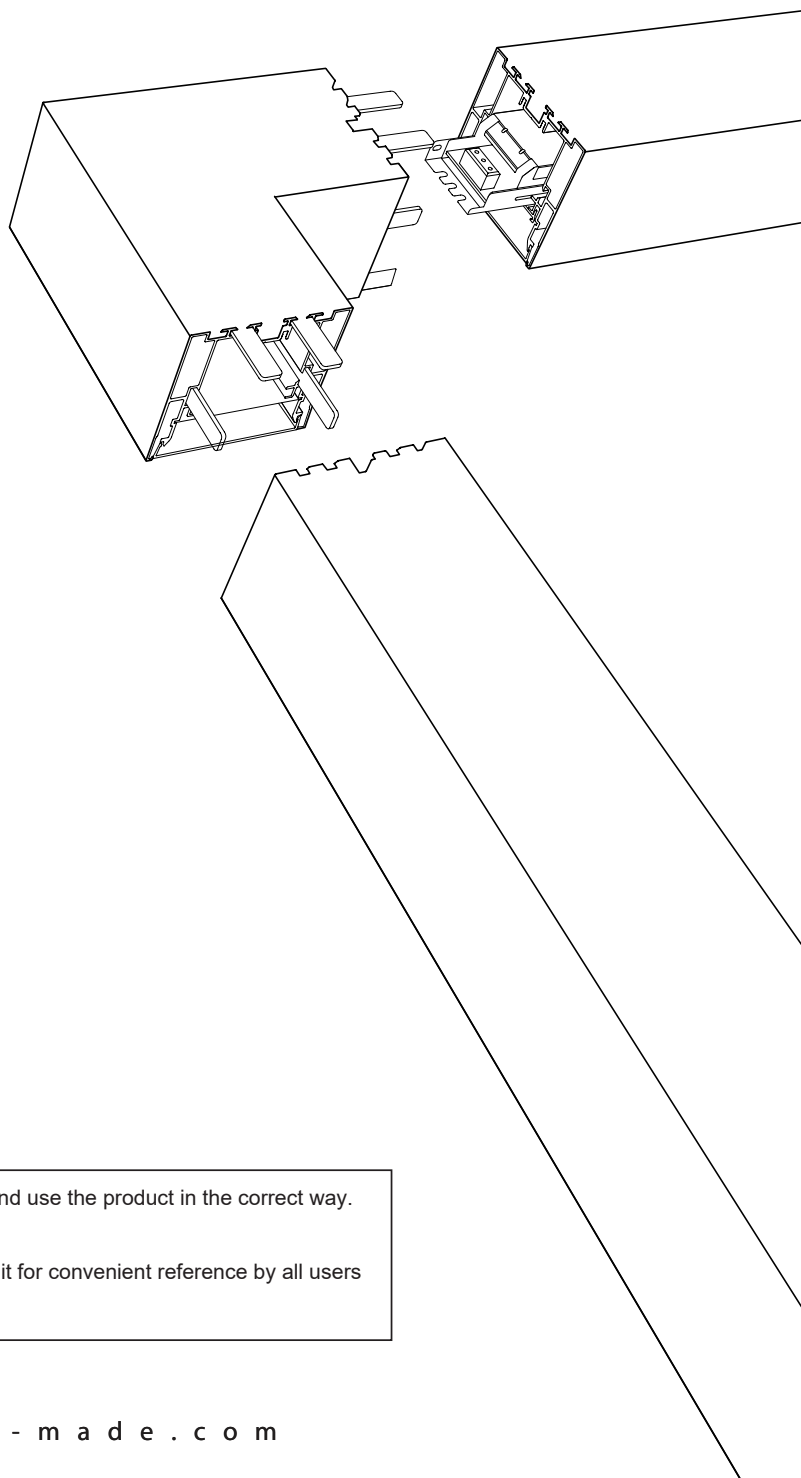

Please read the manual carefully before installation and application, and use the product in the correct way.
Instructions on accessories are included in the manual.
Please properly maintain the manual after reading and understanding it for convenient reference by all users
of the product in the future.

CONTENTS

01	Components	01
02	Installation	
	Surface-mounted	02
	Pendant	05
	Recessed	09
	Wall-mounted	13
03	Cutting	17

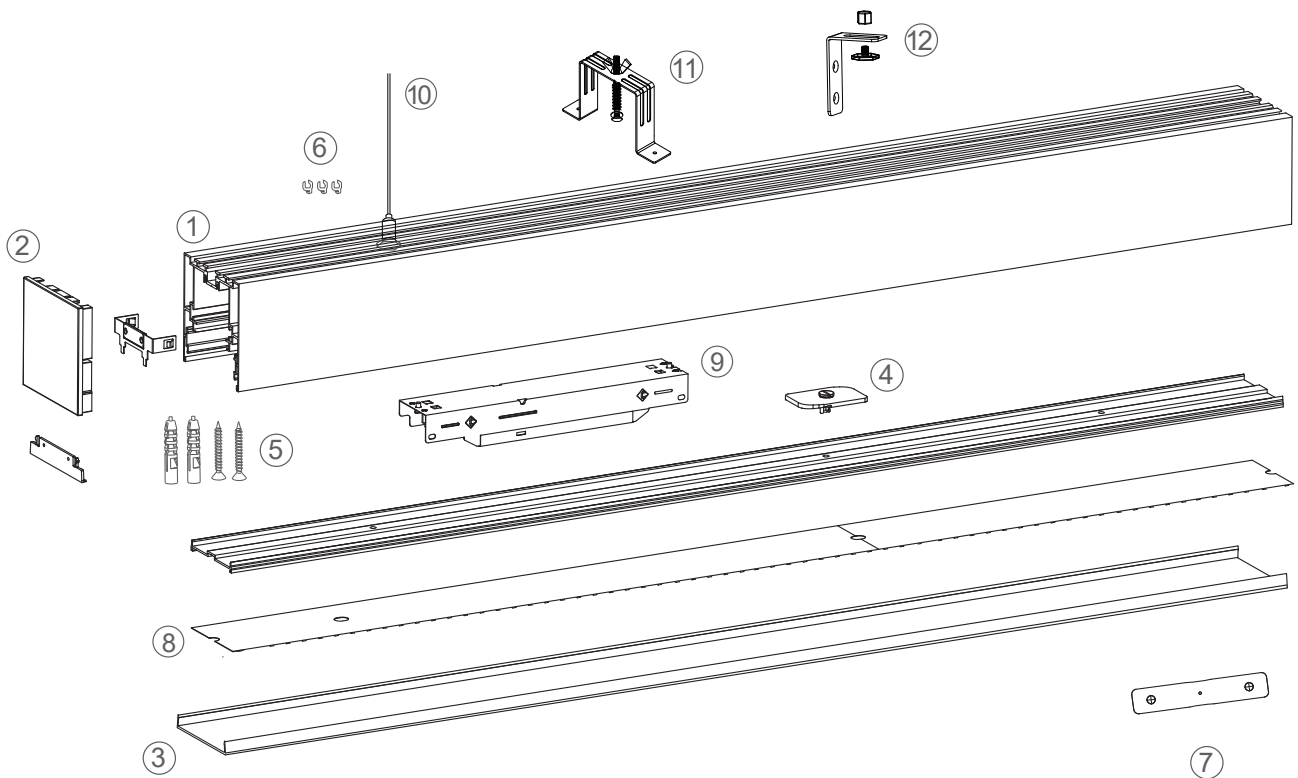

Essentials

- ① Profile x 1
- ② End caps x 2
- ③ Flexible Diffuser x 1
- ④ Carrier clip x 4
- ⑤ Surface-mounted screws x 3
- ⑥ Cable clip

Light source and power supply *

- ⑧ Flexible strip / rigid modular
- ⑨ Power supply

Connectors *

- ⑦ 180° extender

Installation accessories *

- ⑩ Pendant accessories with junction box / pendant accessories
- ⑪ Recessed accessories without trim
- ⑫ Wall-mounted accessories

* Optional accessories

Installation

Surface-mounted 2.5 m

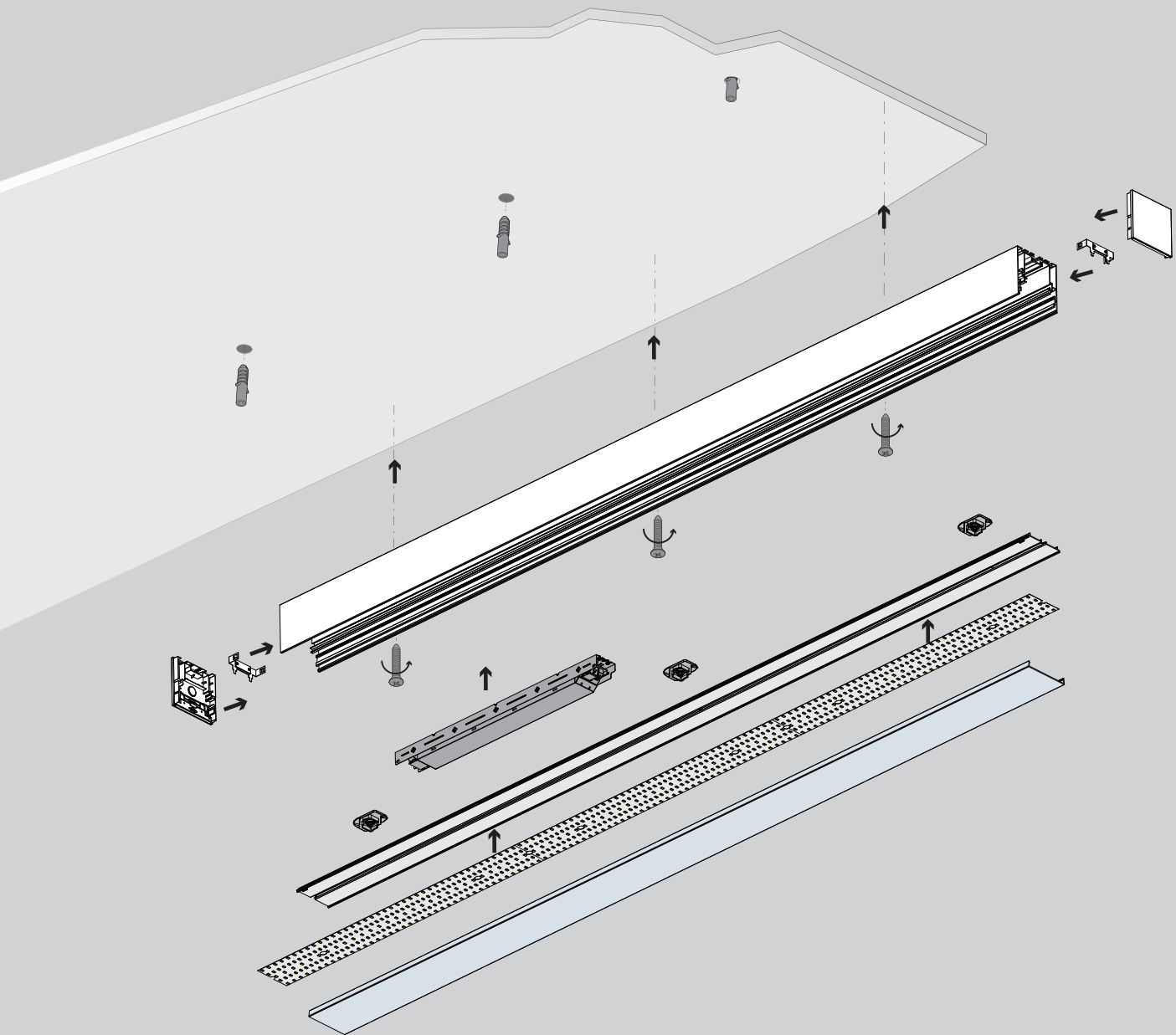

1 Make the 220V wire go through the ceiling
 ⚠ Do not touch with wet hands or there is a risk of electric shock

2 Remove the carrier

3 Punch three $\phi 4$ mm holes into the profile

4 Mount the power supply on the profile
 ⚠ Please read carefully the installation of corners on P07 and P08 if you need to make connections
 ⚠ Do not put the power supply into water or disassemble it by yourself

5 Punch three $\phi 5$ mm holes into the ceiling to match the profile, and then punch the rubber plugs into the holes

6 Make the wire go through from the holes of profile, and then fix profile on the ceiling with screws, and connect the wire to the power supply

⚠ Cut the earth wire and then fix it on the profile with screws (Protect the connection of earth wire with insulation)

7 When ultra-long application, please use the extender accessory to interconnect profiles.

8 a: Place insulation on both ends of the flexible strip and attach it to the carrier

- ⚠ Do not put the strip into water or make the strip exposed to water
- ⚠ Only the strip with copper foil on the back is needed to be protected with insulation

Flexible strip

b: Connect the rigid modular to pins correctly (do not confuse the anode with cathode), and then slide the rigid modular into the carrier

Rigid modular

9 Connect the wire to the power supply (do not confuse the anode with the cathode)

Profile

Driver

LED

Connect to DIM

DIM-
DIM+
LED-
LED+

GND
AC-N
AC-L

+

-

10 Mount the carrier with strip on the profile

90°

11 Install the Flexible diffuser on profile, and cut according to the actual length

- ⚠ Align the diffuser with profile

12 Mount the safety baffles on the both ends of the profile

2 pcs

13 Install the end cap

2 pcs

14 Install the light leak-proof baffle

Click

Pendant 2.5 m

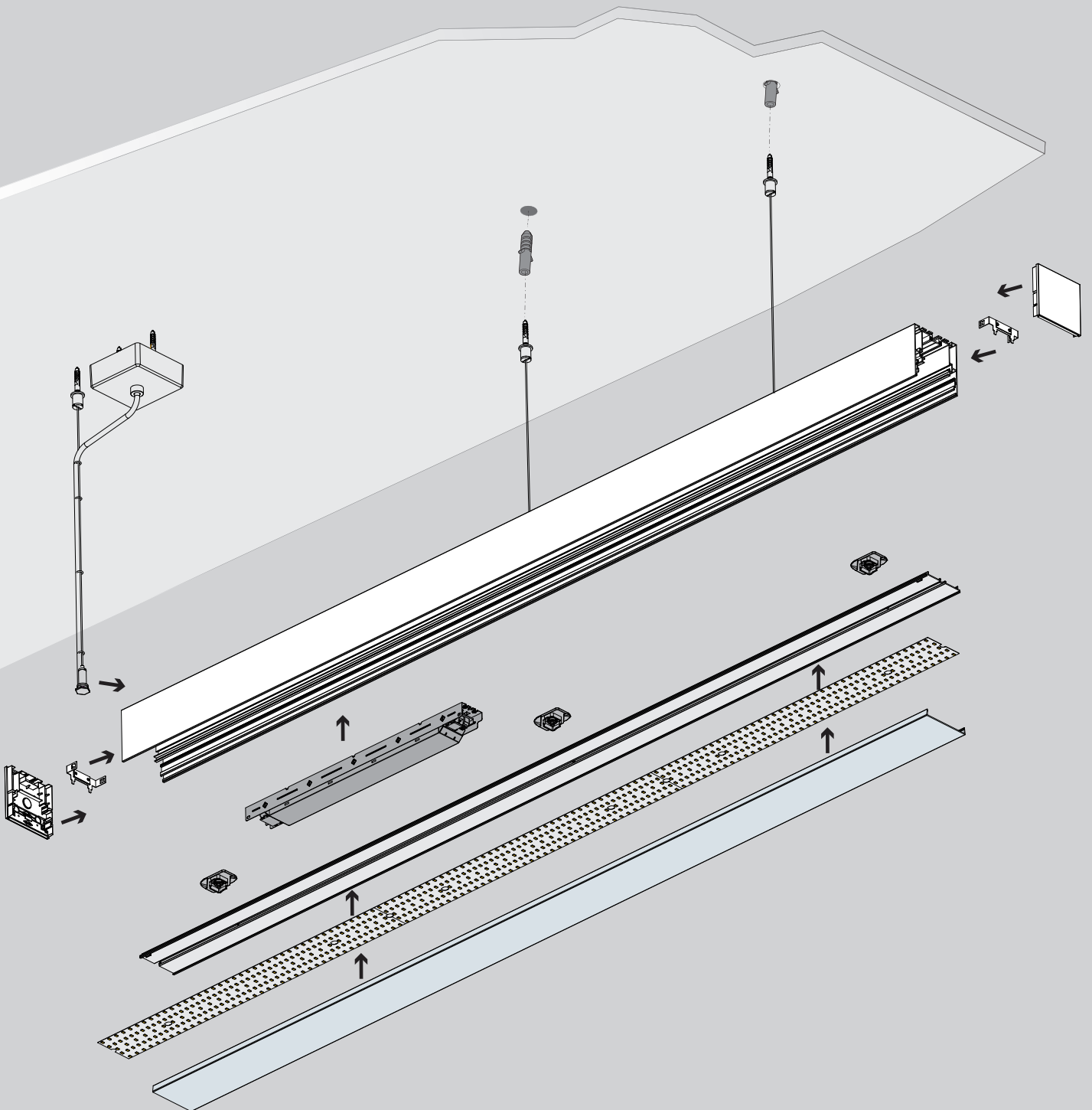

- 1** Make the 220V wire go through the ceiling
 ⚠ Do not touch with wet hands or there is a risk of electric shock

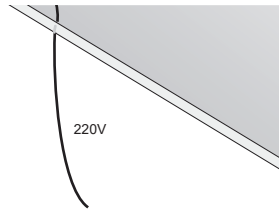

- 2** Punch three $\phi 5$ mm holes into the ceiling to match the profile, and then punch the rubber plugs into the holes

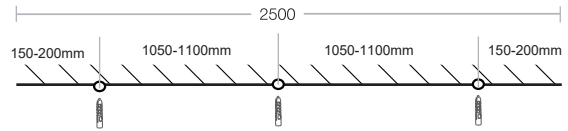

- 3** Fix one end of the wire on the punched hole of ceiling

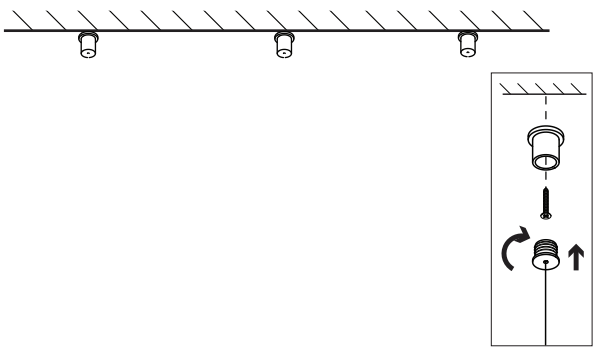

- 4** Fix the junction box on the ceiling and connect it to the wire

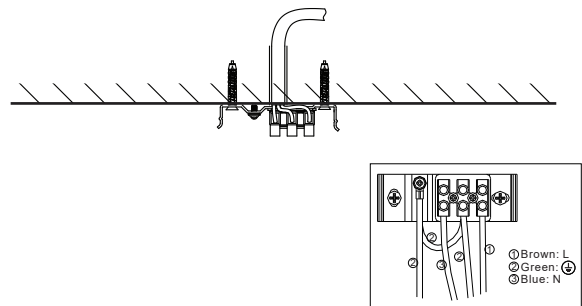

- 5** Remove the carrier

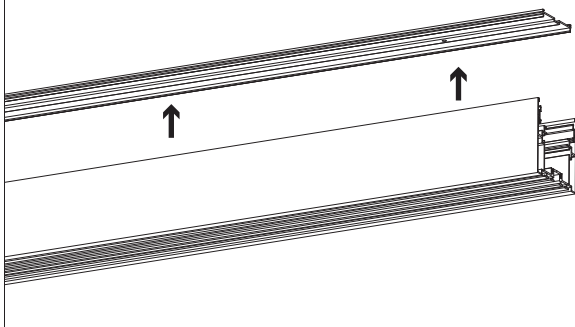

- 6** Mount the power supply on the profile

- ⚠ Please read carefully the installation of corners on P07 and P08 if you need to make connections
- ⚠ Do not put the power supply into water or assemble it by yourself

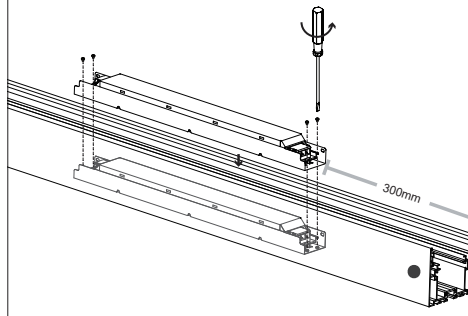

- 7** When ultra-long application, please use the extender accessory to interconnect profiles.

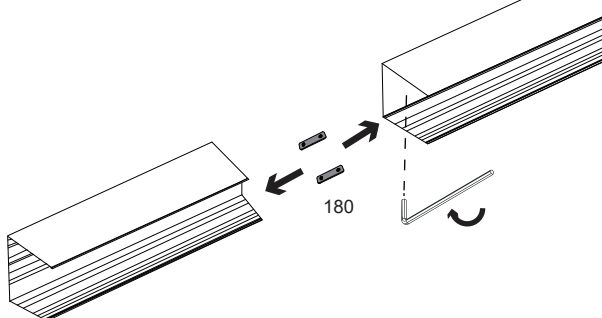

8 a: Place insulation on both ends of the flexible strip and attach it to the carrier

- ⚠ Do not put the strip into water or make the strip exposed to water
- ⚠ Only the strip with copper foil on the back is needed to be protected with insulation

Flexible strip

b: Connect the rigid modular to pins correctly (do not confuse the anode with cathode), and then slide the rigid modular into the carrier

Rigid modular

9 Connect the wire to the power supply (do not confuse the anode with the cathode)

Profile

Driver

LED

- Connect to DIM
- DIM-
- DIM+
- LED-
- LED+
- GND
- AC-N
- AC-L

- ⚠ Cut the earth wire and then fix it on the profile with screws (Protect the connection of earth wire with insulation)

10 Mount the carrier with strip on the profile

90°

11 Install the Flexible diffuser on profile, and cut according to the actual length

- ⚠ Align the diffuser with profile

12 Mount the safety baffles on the both ends of the profile

2 pcs

13 Slide the other end of the pendant wire into the profile, and fix it on the profile

300mm

Slide

14 Install the end cap

2 pcs

15 Install the light leak-proof baffle

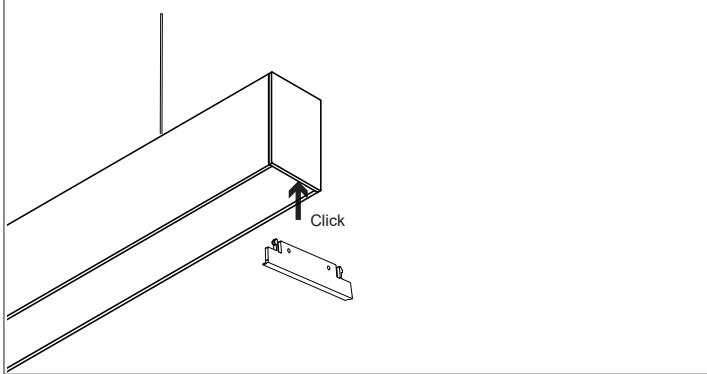

16 Connect the pendant wire to the corresponding position of ceiling

⚠ Please make sure that the pendant wire has been installed firmly

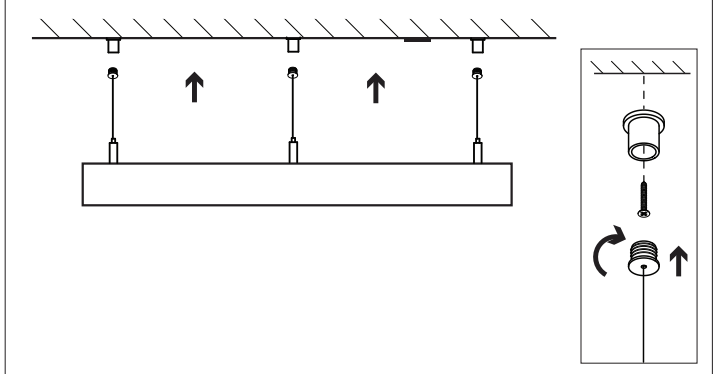

17 Adjust the height of the fixture

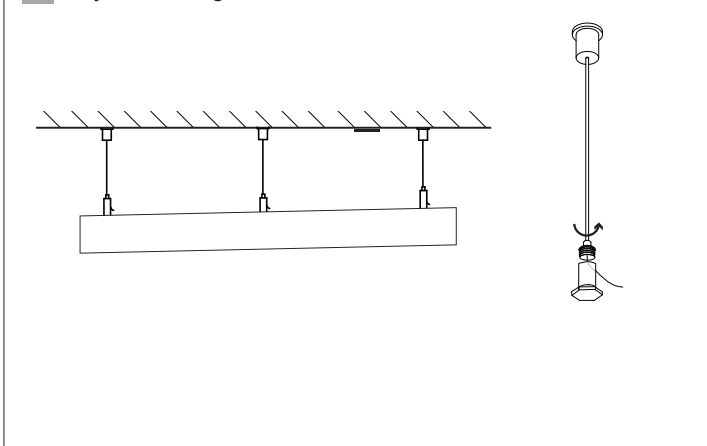

18 Put the power supply wire into the junction box and then connect the power supply wire to the junction wire, and close the junction box

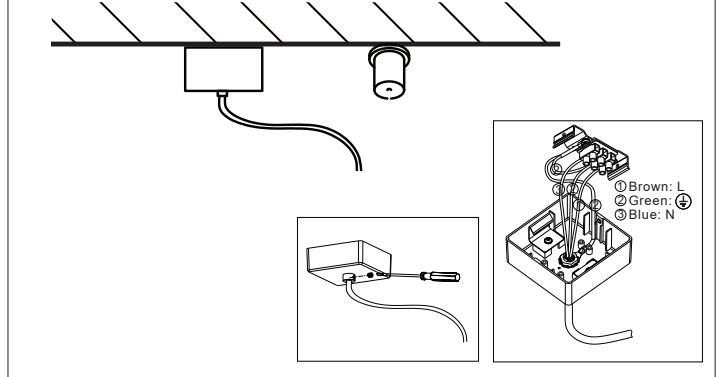

● Brown: L
 ● Green: PE
 ● Blue: N

19 Connect the power supply wire to the pendant wire with clips

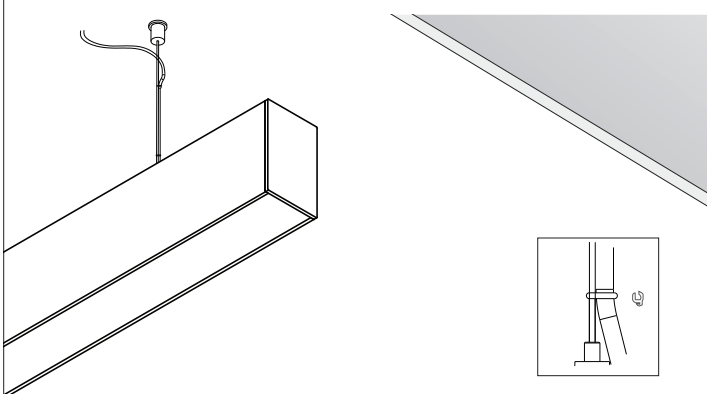

20 Finished

⚠ Please stop using if there are abnormalities like smoke or burnt flavor occur from the fixtures

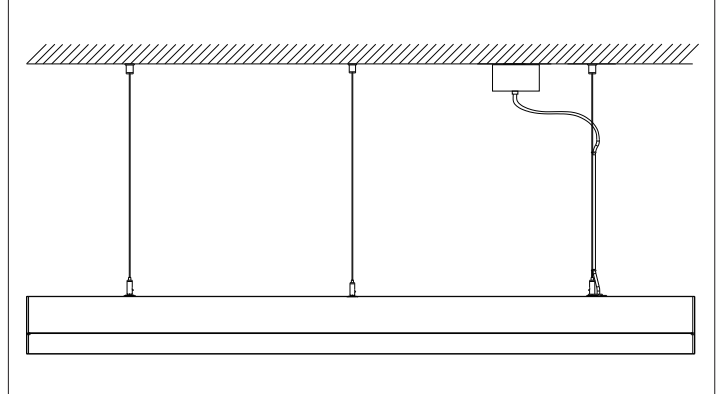

Recessed 2.5 m

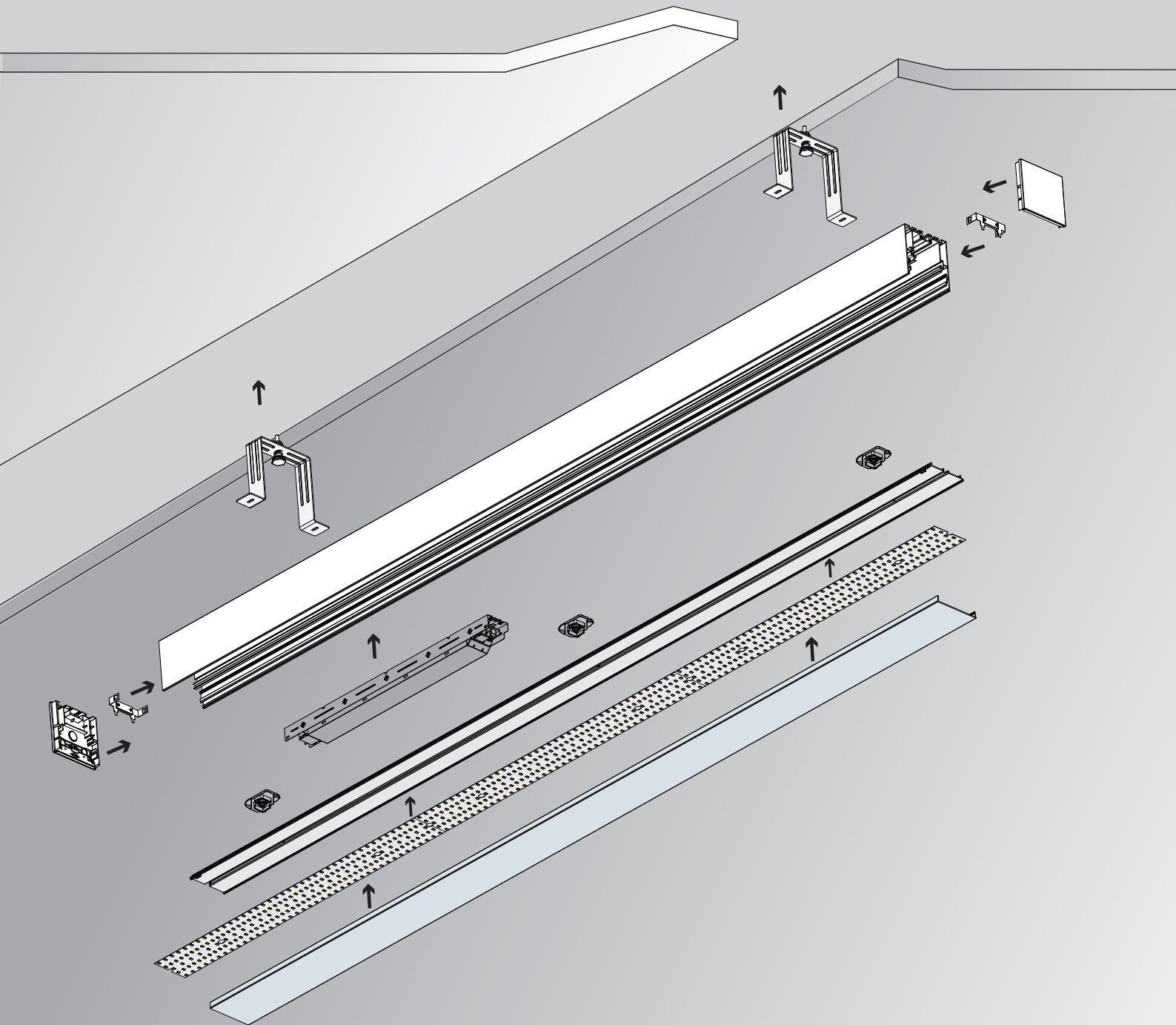

1 Make the 220V wire go through the ceiling
 ⚠ Do not touch with wet hands or there is a risk of electric shock

2 Make a slot the same size as the profile on the ceiling
 ⚠ Dimensional tolerance of slot $\pm 0.5\text{mm}$
 Slot size LINE S5470(F) L(Profile length+9mm)*W61mm*H110mm
 LINE S4067 L(Profile length+9mm)*W47mm*H105mm
 LINE S3360 L(Profile length+9mm)*W40mm*H100mm
 e.g. :The 9mm of LINE S5470(F) refers to the thickness of both end caps (2*3.5mm) + 2mm gap

3 Remove the carrier

4 Mount the power supply on the profile
 ⚠ Please read carefully the installation of corners on P07 and P08 if you need to make connections
 ⚠ Do not put the power supply into water or disassemble it by yourself

5 When ultra-long application, please use the extender accessory to interconnect profiles.

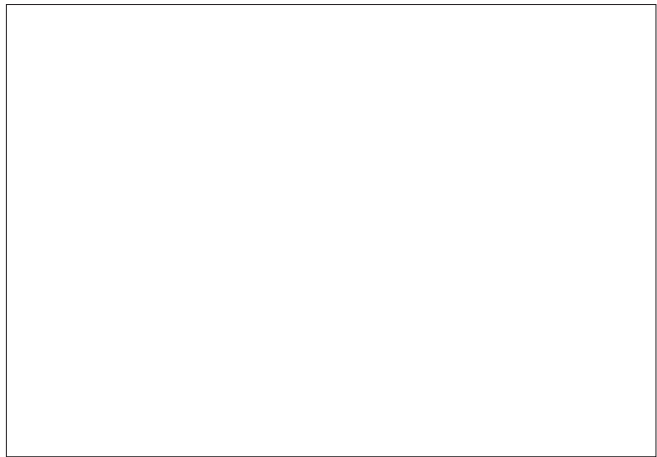

6 a: Place insulation on both ends of the flexible strip and attach it to the carrier
 ⚠ Do not put the strip into water or make the strip exposed to water
 ⚠ Only the strip with copper foil on the back is needed to be protected with insulation

b: Connect the rigid modular to pins correctly (do not confuse the anode with cathode), and then slide the rigid modular into the carrier

7 Connect the wire to the power supply (do not confuse the anode with the cathode)

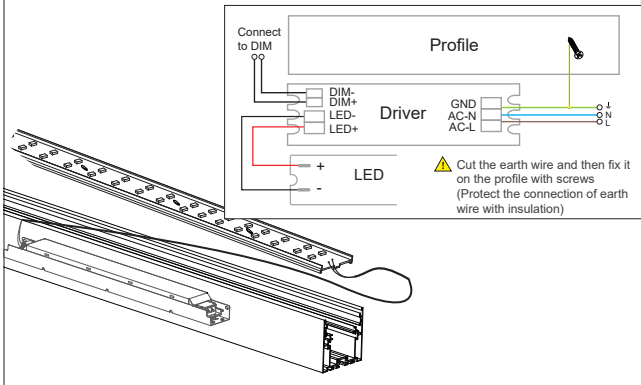

8 Mount the carrier with strip on the profile

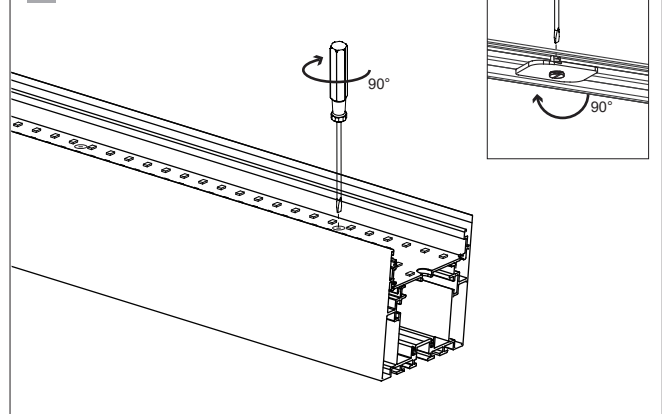

9 Install the Flexible diffuser on profile, and cut according to the actual length

▲ Align the diffuser with profile

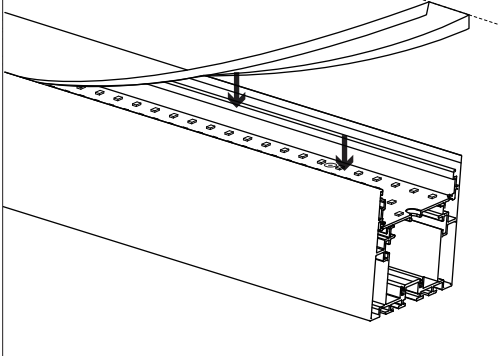

10 Mount the safety baffles on the both ends of the profile

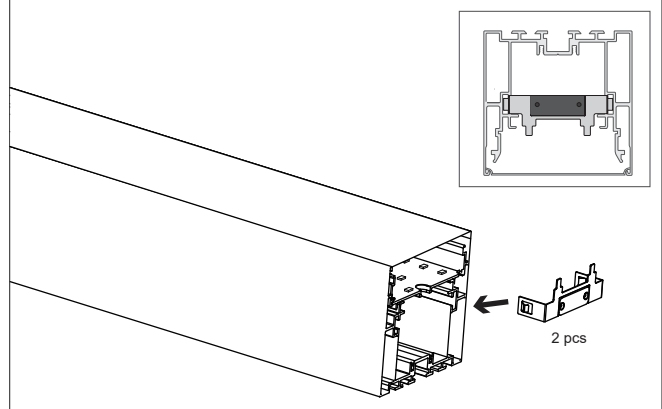

11 Slide the recessed accessories without trim into the profile and then fix it on the profile (adjust the height of recess)

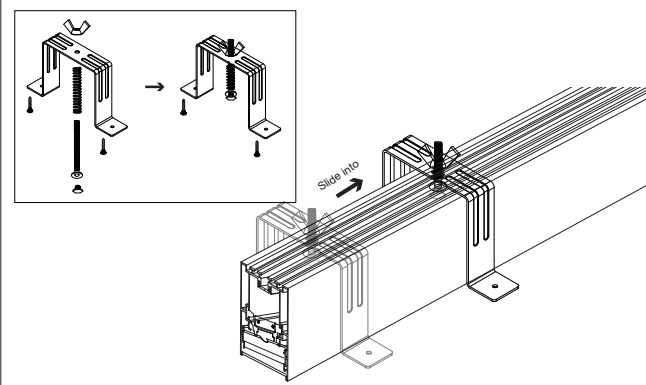

12 Install the end cap

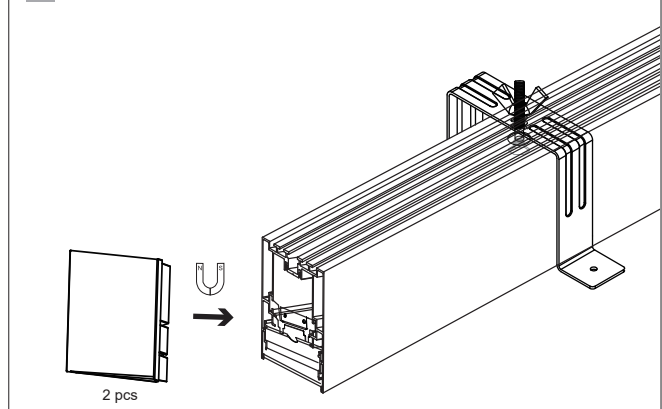

13 Install the light leak-proof baffle

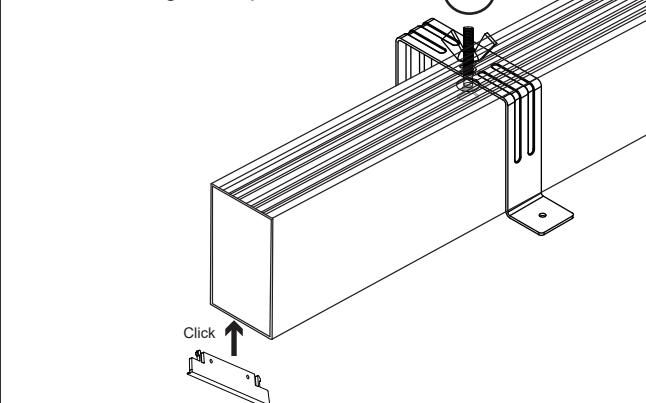

14 Install the profile in the slot of ceiling, and then fix it on the ceiling by recessed clip without trim

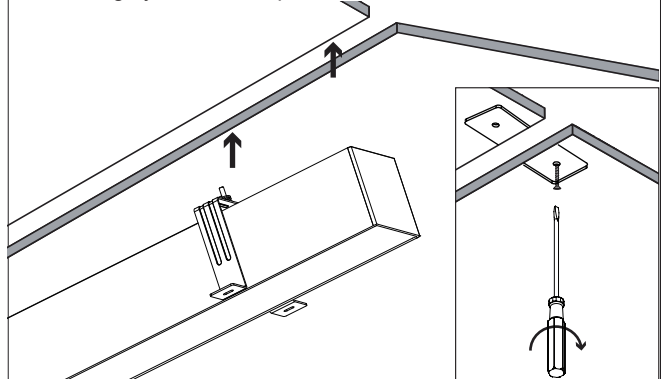

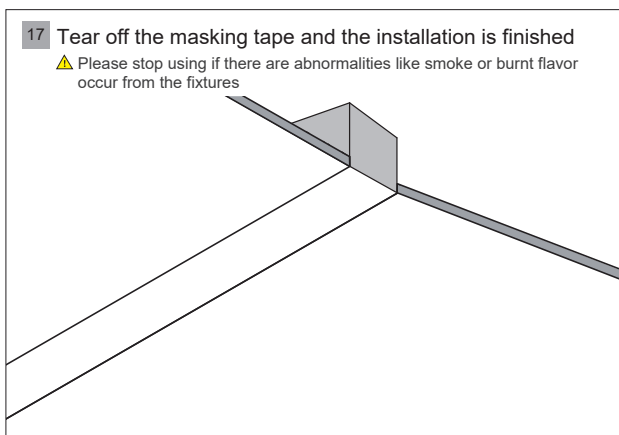
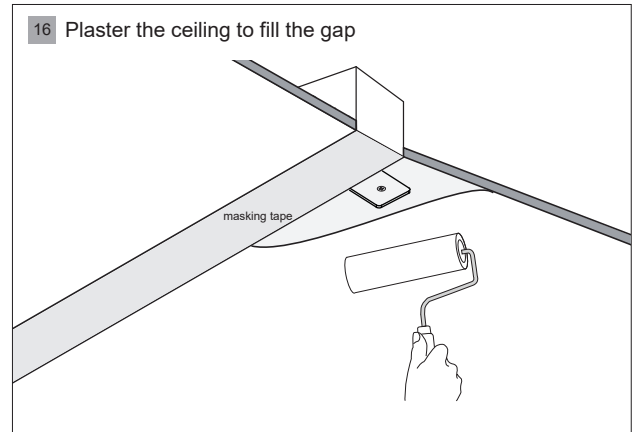
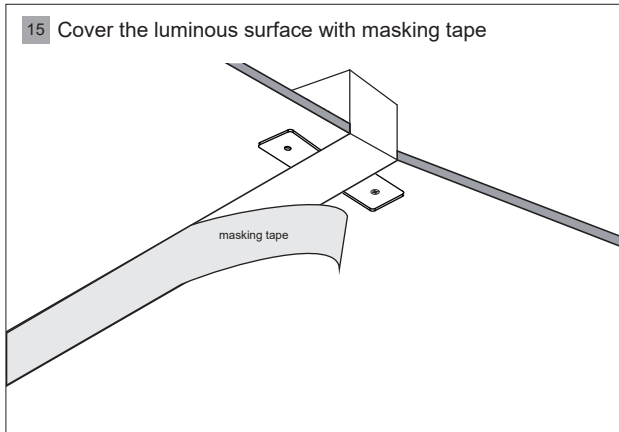

Wall-mounted 2.5 m

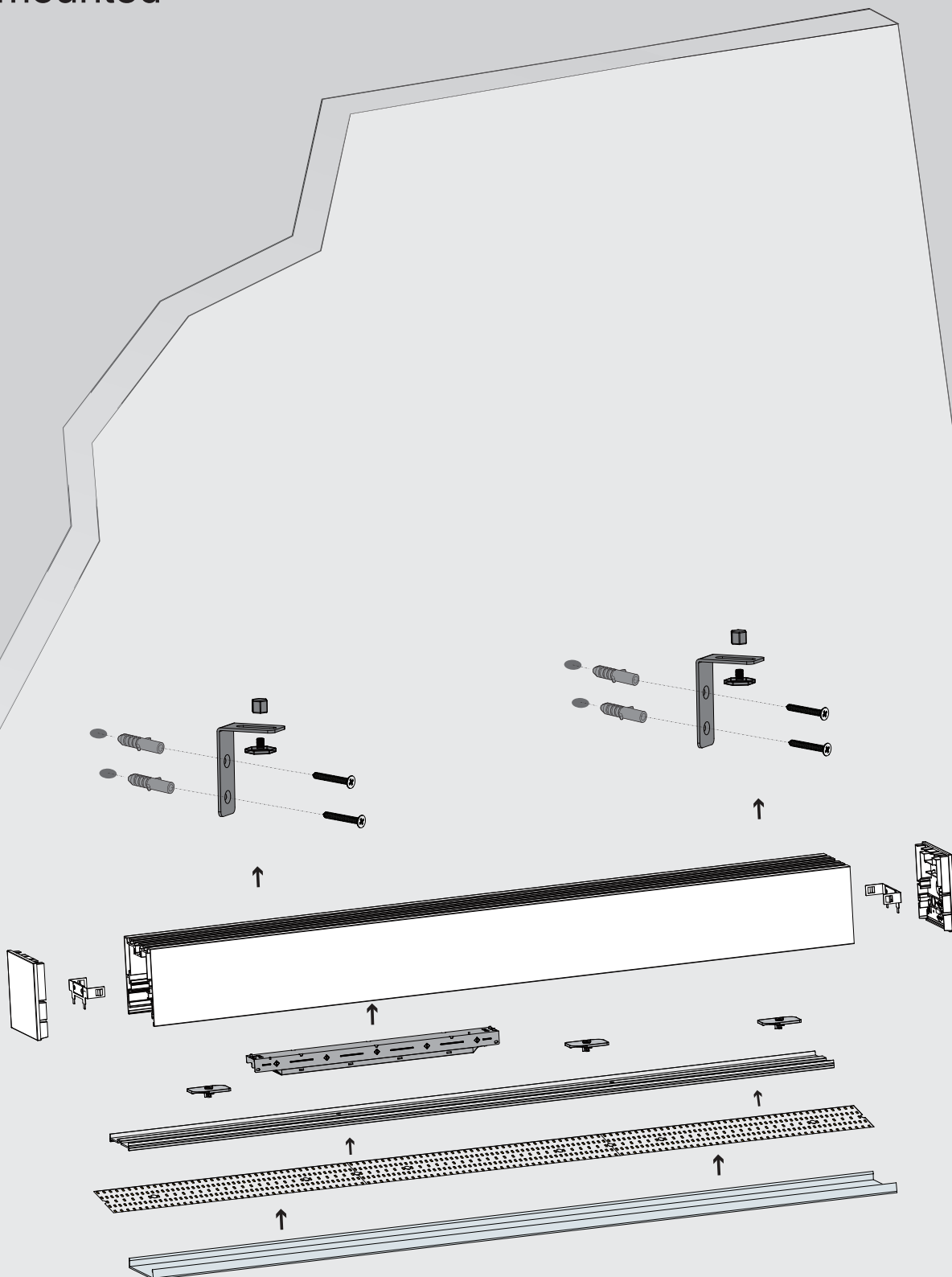

1 Make the 220V wire go through the ceiling
 ⚠ Do not touch with wet hands or there is a risk of electric shock

2 Punch four $\phi 5\text{mm}$ holes into the wall

3 Punch the rubber plugs into the holes

4 Fix the wall-mounted accessories on the wall with screws

5 Remove the carrier

6 Mount the power supply on the profile
 ⚠ Please read carefully the installation of corners on P07 and P08 if you need to make connections
 ⚠ Do not put the power supply into water or disassemble it by yourself

7 When ultra-long application, please use the extender accessory to interconnect profiles.

8 a: Place insulation on both ends of the flexible strip and attach it to the carrier

- ⚠ Do not put the strip into water or make the strip exposed to water
- ⚠ Only the strip with copper foil on the back is needed to be protected with insulation

Flexible strip

b: Connect the rigid modular to pins correctly (do not confuse the anode with cathode), and then slide the rigid modular into the carrier

Rigid modular

9 Connect the wire to the power supply (do not confuse the anode with the cathode)

Profile

Driver

LED

- Connect to DIM
- DIM-
- DIM+
- LED-
- LED+
- GND
- AC-N
- AC-L

⚠ Cut the earth wire and then fix it on the profile with screws (Protect the connection of earth wire with insulation)

10 Mount the carrier with strip on the profile

90°

90°

11 Install the Flexible diffuser on profile, and cut according to the actual length

- ⚠ Align the diffuser with profile

12 Mount the safety baffles on the both ends of the profile

2 pcs

13 Slide the wall-mounted accessories into the profile and then fix it on the profile (adjust the height of recess)

14 Install the end cap

2 pcs

15 Install the light leak-proof baffle

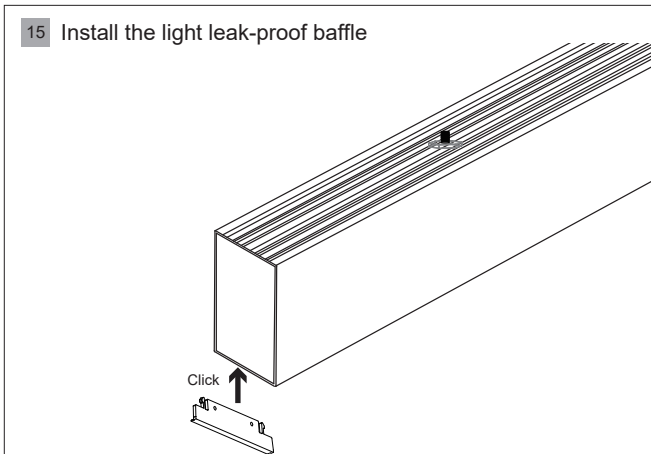

16 Fix the profile on the wall with the wall-mounted screws

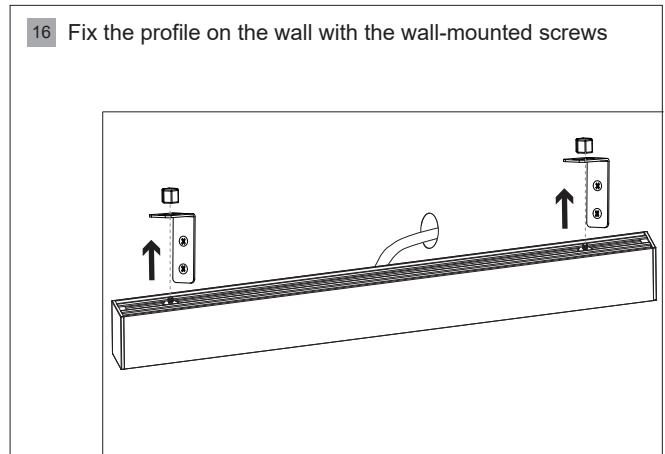

17 Finished

⚠ Please stop using if there are abnormalities like smoke or burnt flavor occur from the fixtures

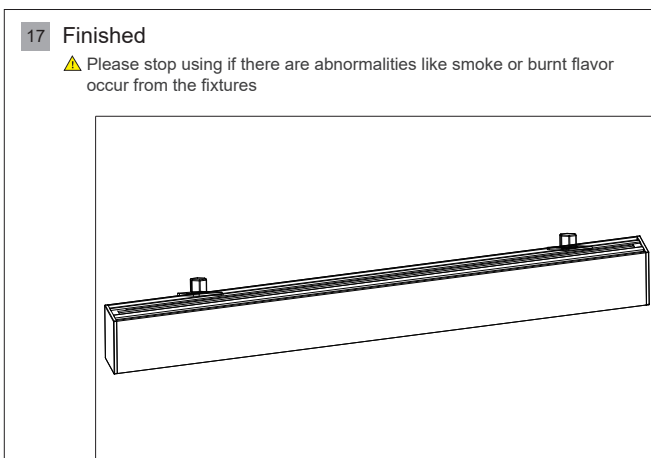

Cutting

1 Remove the carrier

2 Mark the cutting length (The cutting length should be times the length of minimum cutting unit, and profile loss will occur during cutting by about the thickness of the blade), and please make reservation of profile length

3 Cut the profile by cutting machine

- ⚠ It's recommended to set the speed slowly because too high a speed may cause damage to the diffuse.
- ⚠ Please remove the light source during cutting.
- ⚠ Please make sure the profile is firmly fixed during cutting. The surface of fracture shall be ground and smooth without burr after cutting, and the metal chips in the track shall be completely removed.

4 Cut the carrier and strip the same size as the profile and weld the standard wire one end of the strip

5 Punch holes into the carrier

- ⚠ Punch 2 holes for the length shorter than 1.2m; Punch 3 holes for 1.2m-2m long length; Punch 4 holes for 2m-2.5m long length.
- ⚠ The best distance of the hole is 100mm away from the left and right edges and the hole need to be fixed with a carrier clip.
- ⚠ The carrier holes should be aligned with the holes of the minimum unit of the strip.
- ⚠ Avoid the power supply.

Diameter: 4mm

6 Punch holes into the profile for the wire to go out

Diameter: 8mm

7 Mount the carrier clip on the carrier



www.switch-made.com